

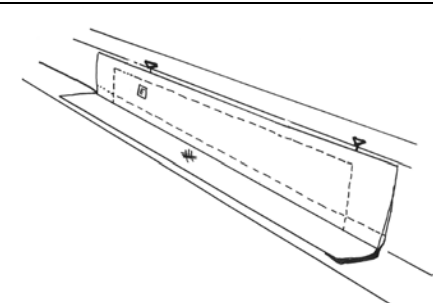
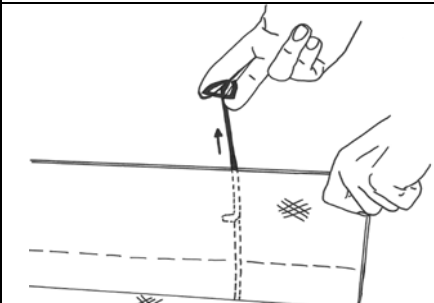
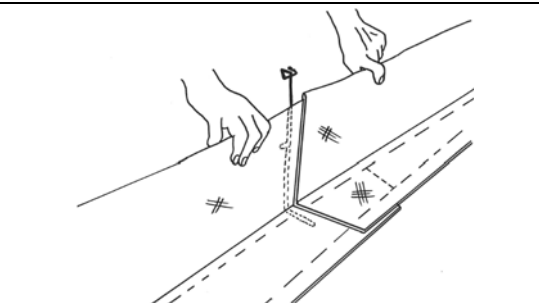
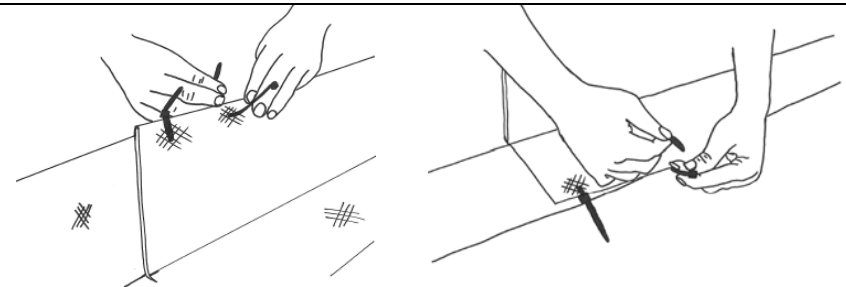
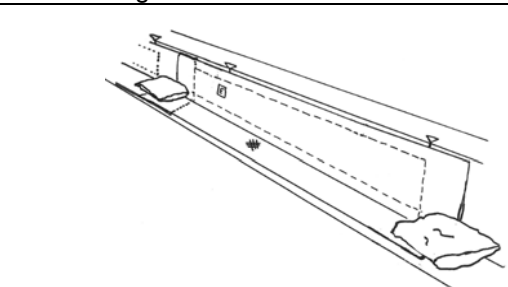

Installation and Maintenance Guidelines: Curb Inlet Guard™ (CIG) Curb Inlet Protection

Definition and Purpose	Curb Inlet Guards (CIG) are installed at Curb Inlets in or near construction sites, or at the base of freshly de-vegetated slopes to reduce the amount of sediment that can reach the storm drain system.
-------------------------------	---

<u>Inlet Size</u>	<u># Modules</u>	Placement – Place with horizontal flap pointing away from curb	Change height – for high openings – extend vertical support pins if necessary	Interconnecting - for Long Curb Openings– overlap the segments so the bottom gasket provides a continuous seal
5.0'	1			
10.0'	2			
15.0'	3			
20.0'	4			
25.0'	5			
30.0'	6			

Interconnecting - for Long Curb Openings – tie together with 16 Gauge galvanized wire or UV Stable Black zip-ties – 4 places – 2 at the top and 2 at the bottom – 4” apart.	Anchoring - Gravel Bags – install gravel bags at each end, at overlaps and in the middle of each segment if necessary. Use 1/3 full gravel bags for low profile and best traffic avoidance. Use clean gravel at drain inlets – not sand.	Notes:
		<ul style="list-style-type: none"> • Select bags with long term UV exposure and toughness for resistance to traffic. • Where not possible to install gravel bags due to traffic proximity, it acceptable to anchor with concrete anchors, or masonry nails – one at each end. Anchor Curb Inlet Guard so that water cannot flow behind it. Use 1” washers.



Maintenance and Inspection

- Repair or replace split or torn Curb Inlet Guards with 16 Gauge Galvanized Wire or Black UV Stable 5" or 7" cable ties (zip-ties).
- Inspect Curb Inlet Guards when rain is forecast. Inspect following rainfall events and at least daily during prolonged rainfall. Perform maintenance as needed or as required.
- Sediment shall be moved when the sediment accumulation reaches 1 inch. Moved sediment shall be incorporated in the project at designated locations.

Important: All information, including illustrations, is believed to be reliable. Users, however, should independently evaluate the suitability of each product for their application. ERTEC Environmental Systems makes no warranties as to the accuracy or completeness of the information, and disclaims any liability regarding its use. ERTEC Environmental System's only obligations are those in the ERTEC Environmental Systems Standard Terms and Conditions of Sale for this product, and in no case will ERTEC Environmental Systems or its distributors be liable for any incidental, indirect or consequential damages arising from the sale, resale, use or misuse of the product. Specifications are subject to change without notice. In addition, ERTEC Environmental Systems reserves the right to make changes, without notification to Buyer, to processing or materials that do not affect compliance with any applicable specification.