

# SWPPP Binder Insert - Curb Inlet Protection

## ERTEC Curb Inlet Guard™

Inlet Size	# of Modules
5.0'	1 Module
10.0'	2 Modules
15.0'	3 Modules
20.0'	4 Modules

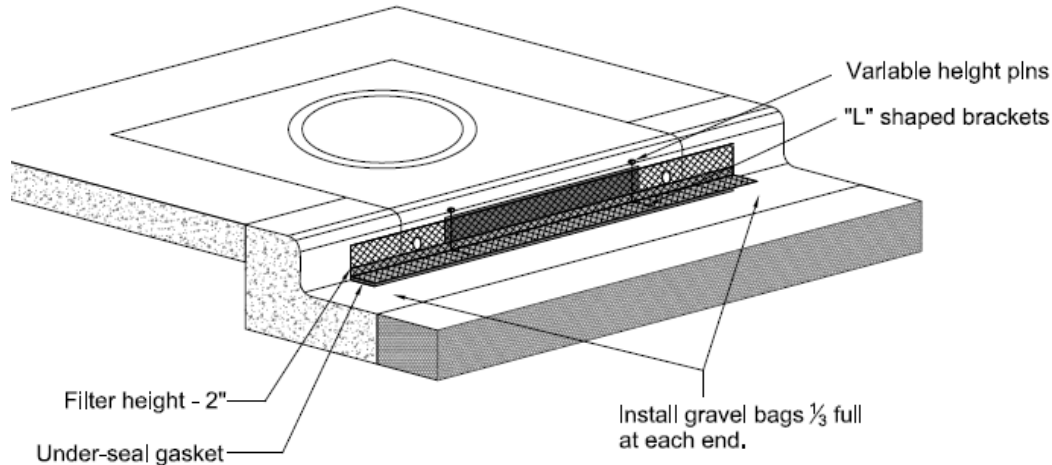

### Definition – ERTEC Curb Inlet Guard

A temporary sediment barrier, “L” shaped, made of high density polyethylene (HDPE) with an integrated filter (woven geotextile). During construction, place device over the opening of the curb storm inlet near where soil is disturbed (See drawings).

### Purpose

Storm drain inlet protection is used to intercept sediment laden water at the curb gutter opening and prevent sediment, debris and associated pollutants from entering the storm water underground pipe systems. The barrier reduces water velocity which in turn causes heavier soil particles to be deposited in front. While allowing flow through the module, the barrier filters certain smaller sized particles from suspension and prevents them from flowing through the device and into the pipes. Excessive flows are passed over the top of the filter. Advantages are that it is effective, durable, re-usable, easily installed and cleaned.

### Conditions Where the Practice Applies

It is recommended for use in curb openings in front of areas with small drainage areas. Generally, the drainage areas should be less than 1/3 acre and the total for inlets in series should be 1 acre or less with slopes flatter than 5 percent in the contributing drainage area.

### Design Criteria

- Geo-textile Filter: See drawing for dimensions. Apparent Opening Size (AOS) = 425 micron integrated particle filter. Flow rate (ASTM D-4491) = 145 gpm/ft<sup>2</sup>. Provide a bypass over the top.
- Outer Jacket Material: HDPE. For detailed characteristics contact ERTEC. Module weight = 3.5 lbs. Module height = 7.5". Module length/opening size protected = 6' 3"/5.0 ft. Service temperature (deg F) = -30 to 160.
- Install barrier with the anchor flap facing upstream toward the street. Place small gravel bags containing clean, pea-sized graded gravel on each end of the flap and butt the bags tightly against the curb to keep water in the gutter from flowing behind the filter. Additional bags can be placed on the flap as necessary; however, bags should be kept off the street for safety reasons. The porosity of the gravel bag should allow for design flow rate through the bag. The bag should be durable enough to last the period of intended use. If the storm inlet opening exceeds 5.0' in length, overlap one of module by 6" over end of adjoining module for a continuous run until the desired length is achieved. When overlapping, note the gasket material under the flap is cut-out where the flap of top module sits on flap of bottom module.

### Maintenance

Perform maintenance as required. Inspect following rainfall events and at least daily during prolonged rainfall. Maintain to provide an adequate sediment holding capacity. Trash shall be removed daily and sediment shall be removed when the sediment accumulation reaches 1 inch. Removed sediment shall be incorporated in the project at designated locations or disposed-of outside the project or in conformance with requirements. Remove the device after final stabilization has been achieved.



**Curb Inlet Guard™**  
**ERTEC Environmental Systems**  
[www.ertecsystems.com](http://www.ertecsystems.com)  
 Toll Free: 866-521-0724